

Cylinder Clevis



E&E SPECIAL PRODUCTS
7200 MILLER DRIVE
WARREN, MI 48092
586-978-3377 / 586-978-3378 FAX



Features:

- ❑ Easily Attaches to Cylinder Rods.
- ❑ Excellent Load Capacity.
- ❑ Clevis Pin with Retainer.
- ❑ Air or Hydraulic Applications.
- ❑ Mechanical Locking.

Design Features

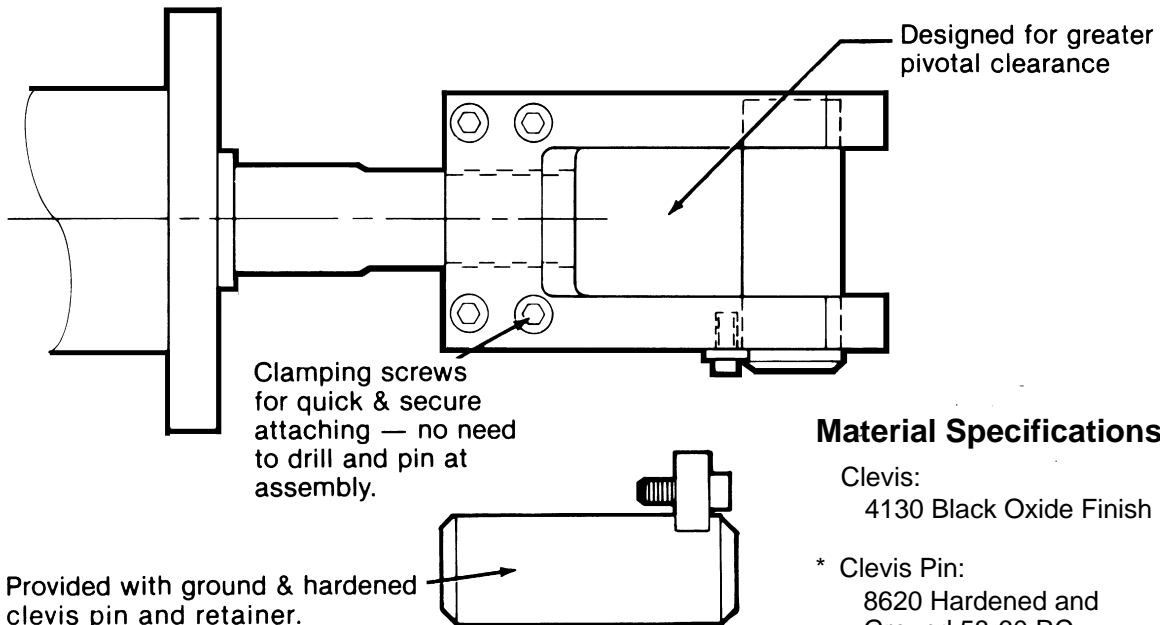

Material Specifications:

Clevis:
4130 Black Oxide Finish

* Clevis Pin:
8620 Hardened and
Ground 58-60 RC
.001 Below Nominal
Dimension + .0000/- .0005

* Available with pipe tap.
Refer to page D15 for dimensions.

Cylinder Clevis

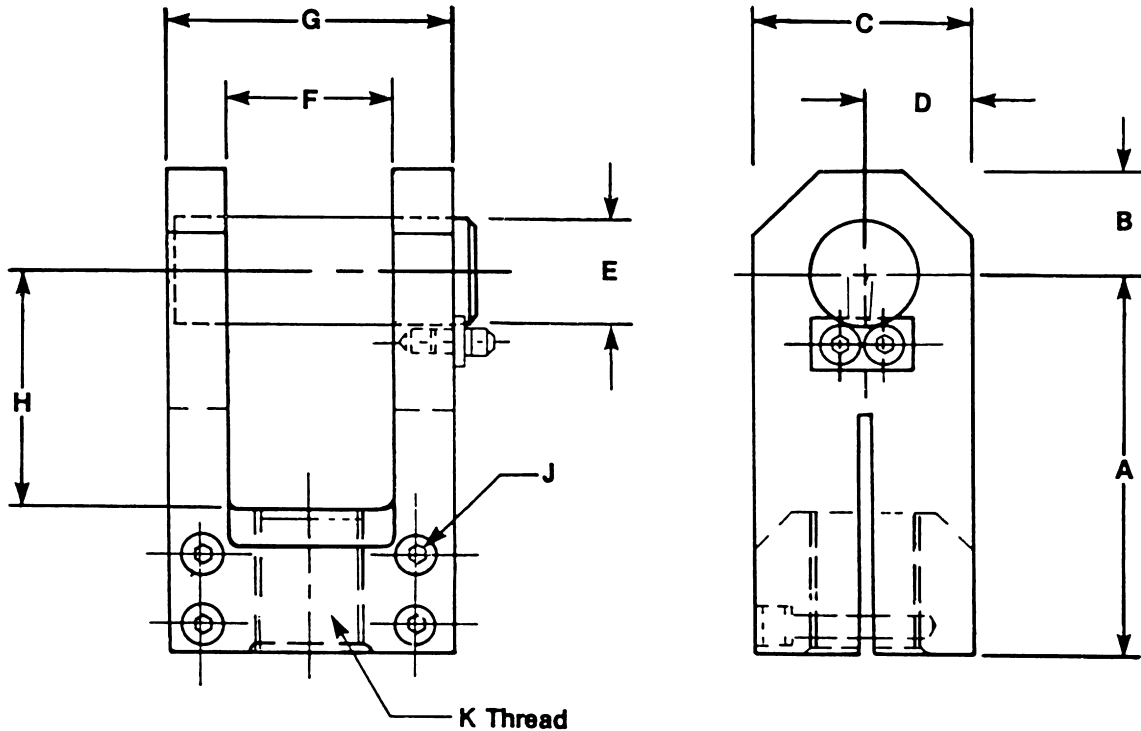

CAD FILE NAME	PART NUMBER	DIMENSIONS									
		A	B	C	D	E#	F	G	H	J	K
E-1570	E-1570	2.30	.70	1.50	.75	.625	1.00	2.00	1.50	5/16 x 3/4 2 SCREWS	7/16-20
E-1571	E-1571	2.30	.70	1.50	.75	.625	1.00	2.00	1.50	5/16 x 3/4 2 SCREWS	1/2-20
E-1572	E-1572	3.30	1.00	2.00	1.00	1.000	1.50	2.50	2.00	3/8 x 1-1/4 2 SCREWS	3/4-16
E-1573	E-1573	3.30	1.00	2.00	1.00	1.000	1.50	2.50	2.00	3/8 x 1-1/4 2 SCREWS	7/8-14
E-1574	E-1574	4.40	1.25	2.50	1.25	1.250	1.80	3.00	2.70	3/8 x 1-1/2 4 SCREWS	1-14
E-1575	E-1575	4.40	1.25	2.50	1.25	1.250	1.80	3.00	2.70	3/8 x 1-1/4 4 SCREWS	1-1/4 -12
E-1576	E-1576	5.40	1.50	3.00	1.50	1.500	2.30	4.00	3.40	3/8 x 1-1/2 4 SCREWS	1-1/2 -12
E-1577	E-1577	6.00	1.75	3.50	1.75	1.750	2.50	4.50	3.80	3/8 x 2.00 4 SCREWS	1-3/4 - 12
E-1578	E-1578	7.40	2.00	4.00	2.00	2.000	3.30	6.00	4.50	3/8 x 2-1/4 6 SCREWS	2-1/4 - 12

#Clevis pins are furnished and ground .001 below nominal "E" dimension +.0000/-.0005.

Note: Add "PT" after part number when pipe tap is desired, i.e.: E1970-PT.

SAFE LOAD IN POUNDS								
E1570	E1571	E1572	E1573	E1574	E1575	E1576	E1577	E1578
7,950	7,950	10,250	10,250	16,000	16,000	27,000	36,000	56,000

Cylinder Clevis

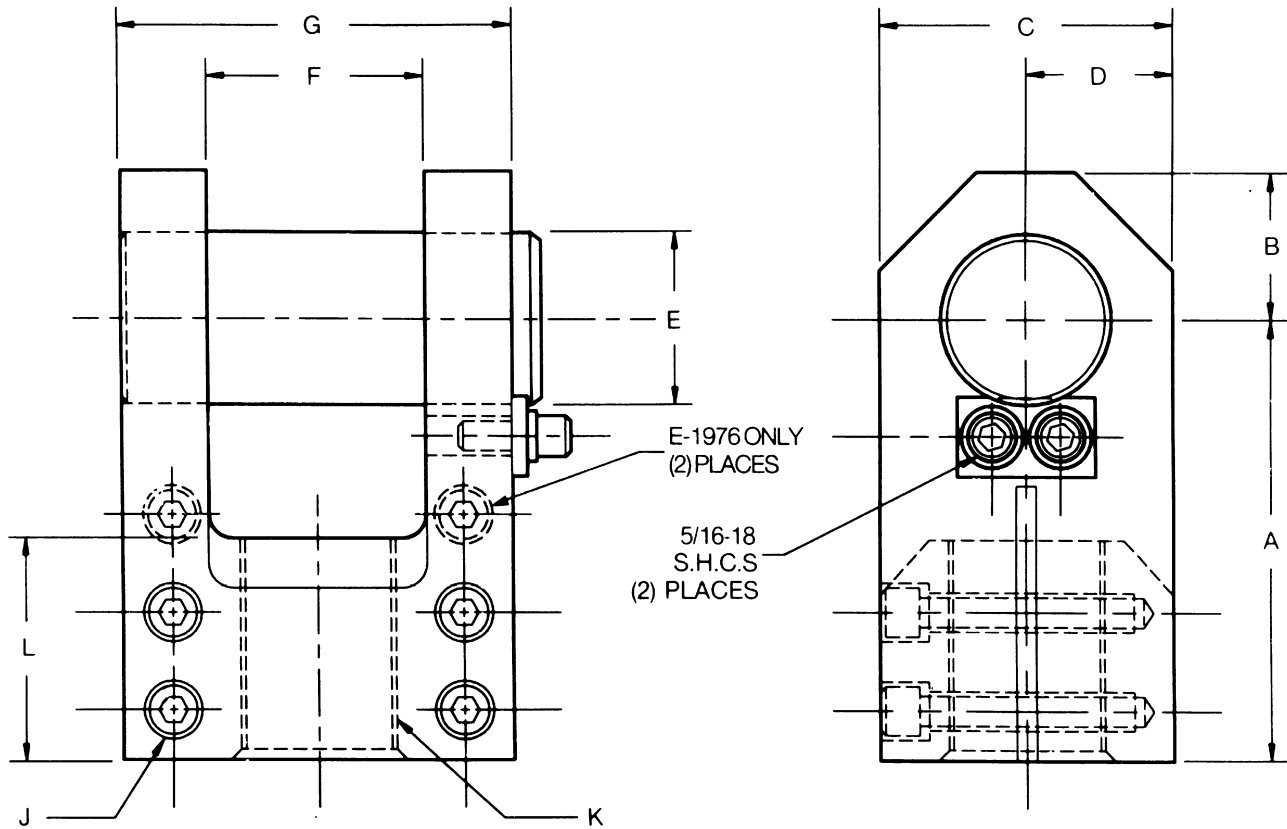

CAD FILE NAME	PART NUMBER	A	B	C	D	E#	F	G	J	K	L
E-1970	E-1970	1.50	.70	1.50	.75	.500	1.00	2.00	5/16 x 1 2 SCREWS	7/16 - 20	.75
E-1971	E-1971	2.375	1.00	2.00	1.00	.750	1.50	2.50	3/8 x 1-1/4 2 SCREWS	3/4 - 16	1.12
E-1972	E-1972	3.125	1.25	2.50	1.25	1.000	1.75	3.00	3/8 x 1-3/4 4 SCREWS	1 - 14	1.62
E-1973	E-1973	4.125	1.25	2.50	1.25	1.375	1.75	3.00	3/8 x 1-3/4 4 SCREWS	1-1/4 - 12	2.00
E-1974	E-1974	4.50	1.50	3.00	1.50	1.750	2.25	4.00	3/8 x 1-3/4 4 SCREWS	1-1/2 - 12	2.25
E-1975	E-1975	5.50	1.75	3.50	1.75	2.000	2.50	4.50	3/8 x 2-3/4 4 SCREWS	1-7/8 - 12	3.00
E-1976	E-1976	6.50	2.00	4.00	2.00	2.500	3.25	6.00	3/8 x 3-1/4 6 SCREWS	2-1/4 - 12	3.50

#Clevis pins are furnished and ground .001 below nominal "E" dimension +.0000/- .0005.

Note: Add "PT" after part number when pipe tap is desired, i.e.: E1970-PT.